

e-MINI MY LITE

ELECTRIC SMALL DEICING UNIT



Vestergaard Company has launched the e-Mini MY Lite - our well-known smallest aircraft deicer - in a sustainable version on a fully electric 12 t chassis. The first version is equipped with a 40 kWh lithium-ion battery with enough capacity to drive up to approx. 30 km and up to 15-20 deicing operations on one charge.

The Elephant® e-Mini MY Lite is a simplified, off the shelf version of the traditional Elephant® MY introduced especially for servicing smaller to medium-sized aircraft. Either as a supplement to add flexibility to existing de-icing operations, or as the back-bone de-icer for airport operations, frequented by aircraft types of up to, and including, Boeing 757/767.

The aim of the e-Mini MY Lite is to make quality deicers for servicing smaller to medium-sized aircraft available at lower cost. The e-Mini MY Lite is a 4,000 liter version with two tanks designed for operations using premix type I fluid for deicing and pure type II/IV for anti-icing

The Vestergaard e-chassis is based on standard industrial, electronic components, which are thoroughly tried and tested. The e-Mini MY Lite can be equipped with either a diesel or electric heater for fluid.

With the e-Mini MY Lite operators can now operate equipment in closed gate areas with zero emission and no small particle pollution. Furthermore, noise is practically eliminated as there is no need for engine idle on the ramp.

MAJOR ADVANTAGES

- Sustainable deicing unit
- Easy to operate
- Easy access for the operator
- Virtually noise free
- Unsurpassed unit lifetime and low maintenance costs
- Off the shelf and less costly

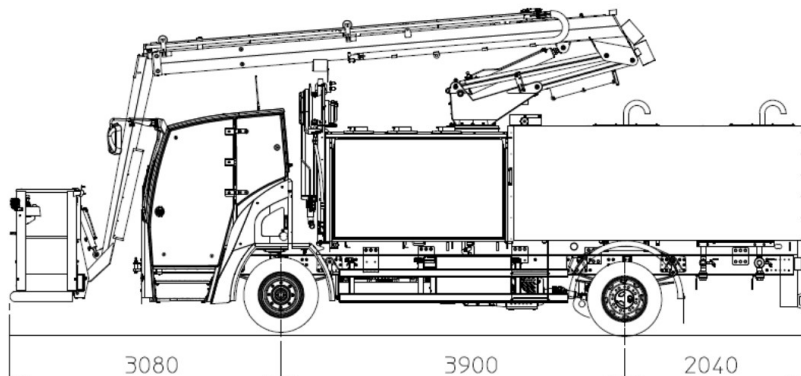

COMPANY
VESTERGAARD

e-MINI MY LITE

TECHNICAL SPECIFICATIONS

- **Chassis:**
 - Vestergaard e-1240
- **Colour scheme:**
 - Chassis cabin and tank section: White colour (RAL 9016 equal to Volvo 1107)
 - Boom system: Light Grey (RAL 7040)
- **Tank:**
 - 3000 liter pre-mix type I, 1000 liter type II/IV
 - Stainless steel tanks with 5 year warranty
 - Tank 2 is thermal insulated from tank 1
 - Pipes for bottom filling As standard capped with 2" threads
- **Heating System**
 - 160 kW diesel total heating capacity Two separate heaters in parallel setup
 - Batch heating system, as ensure a quick start-up time.
 - Automatic fire extinguish system Novec 1230
 - Optional electric heater
- **Fluid systems**
 - One circulation pump Type-I compatible max. flow rate 210±10 l/min.
 - One pump diaphragm Type-I/II/IV compatible max. flow rate 120±10 l/min
 - Separate tubing of Type I and Type II/V fluid to basket To reduce spillage by change in sprayed fluid type
 - Onboard filling function for both tanks
- **Performance - lift system:**
 - Maximum lift height 8.6 meter to basket floor
 - Fully proportional operation of boom system.
 - Open basket design
 - Working LED-light at basket
 - Max. rated load in basket: 205 kg
 - Boom construction sandblasted and quality coated corrosion class C4-high
- **Information display in truck cabin**
 - Tank level indication
 - Temperature in tank 1 and batch tank
- **Options:**
 - Ground gun in left side behind truck cabin. Max hose length 15 meter Only able to spray tank 1 fluid
 - Access into tanks via manhole covers and steps/ladder left side
 - Spare wheel front/rear
 - Basket Side Cover To protect the operator in the basket from the weather
 - Amber flashing beacon Located at hydraulic tank
 - Side guard on chassis – left or/and right side In order to prevent underride collisions
 - Coupling for bottom filling Stortz, Camlok, Guillemain, Todo, Elaflex
 - Hot at nozzle for pre-mix system To insure instant heated fluid at spray gun in basket
 - Heat or air-condition
 - Enclosed cabin with heating
 - 12 kw charger three-phase 400 volt, 32 amp (20-80% charge in 3 hours)

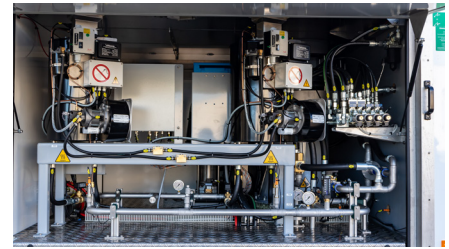

For questions and requests for further information please contact:

Vestergaard Company A/S

Skullejerg 31 • Gevninge
DK-4000 Roskilde • Denmark
Tel: +45 4642 2222
sales@vestergaardcompany.com
www.vestergaardcompany.com

Vestergaard Company Inc.

9103 W. Rte. 120
McHenry, IL 60051 • USA
Tel: +1 815 759-9102
Toll free: +1 888 759-9118
usa@vestergaardcompany.com

Vestergaard Company SASU

Bâtiment 3450 A, 4, Rue du Té
93290 Tremblay-en-France • France
Tel.: +33 1 30 34 55 87
france@vestergaardcompany.com

Vestergaard Company Ltd.

Pinthong Industrial Estate
789/50 Moo 1, Nongkham
Chonburi 20230 • Thailand
Tel: +66 (0) 38 348 630
asia@vestergaardcompany.com

Caution: Specifications are advisory only, and will vary. Please request exact data.

