

ELEPHANT® MINI MY LITE



QUALITY DEICER AT LOWER COST FOR SMALL/MEDIUM AIRCRAFT

Based on the well-established, firm technical base in the Elephant family of aircraft de-icers, the Vestergaard Elephant® Mini My Lite is introduced especially for servicing smaller to medium-sized aircraft. Either as a supplement to add flexibility to existing de-icing operations, or as the back-bone de-icer for airport operations, frequented by aircraft types of up to, and including, Boeing 757/767.

The aim with the Mini MY Lite is to make quality deicers for servicing smaller to medium-sized aircraft available at lower cost.

The new Mini MY Lite is a 4,000 liter version with two tanks designed for operations using premix type I fluid for deicing and pure type II/IV for anti-icing.

► Options:

- Basket Side Cover To protect the operator in the basket from the weather
- Reverse camera
- Level display at side of tank section
- Flow sensor for sprayed fluid
- Basket sensor for safety
- Additional spray gun in basket
- Side guard on chassis – left or/and right side In order to prevent underride collisions
- Coupling for bottom filling Stortz, Camlok, Guillemín, Todo, Elaflex
- Hot at nozzle for pre-mix system To insure instant heated fluid at spray gun in basket
- Amber flashing beacon Located at hydraulic tank
- Ground gun in left side behind truck cabin. Max hose length 15 meter Only able to spray tank 1 fluid
- Access into tanks via manhole covers and steps/ladder left side
- Spare wheel front/rear

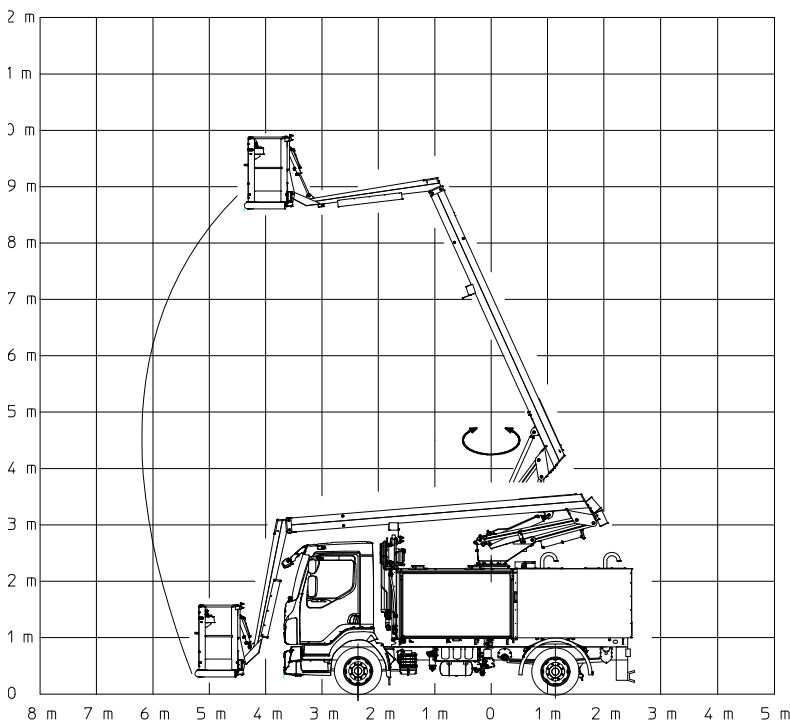

MAJOR ADVANTAGES

- Off the shelf
- Less costly
- Perfect for smaller operations
- High maneuverability



ELEPHANT® MINI MY LITE



TECHNICAL SPECIFICATIONS

- **Chassis:**
 - Volvo FL250, 4 x 2 (Vestergaard spec.) EURO 6 engine
 - Automatic gearbox 6-Speed Alison306
- **Colour scheme:**
 - Chassis cabin and tank section: White colour (RAL 9016 equal to Volvo 1107)
 - Boom system: Light Grey (RAL 7040)
- **Tank:**
 - 3000 liter pre-mix type I, 1000 liter type II/IV
 - Stainless steel tanks with 5 year warranty
 - Tank 2 is thermal insulated from tank 1
 - Pipes for bottom filling. As standard capped with 2" threads
- **Heating System**
 - 160 kW diesel total heating capacity. Two separate heaters in parallel setup
 - Batch heating system, as ensure a quick start-up time.
 - Automatic fire extinguish system. Novec 1230
- **Fluid systems**
 - One circulation pump Type-I compatible max. flow rate 210±10 l/min.
 - One pump diaphragm Type-I/II/IV compatible max. flow rate 120±10 l/min
 - Separate tubing of Type I and Type II/V fluid to basket. To reduce spillage by change in sprayed fluid type
 - Onboard filling function for both tanks
- **Performance - lift system:**
 - Fully proportional operation of boom system.
 - Open basket design
 - Working LED-light at basket
 - Max. rated load in basket: 205 kg
 - Boom construction sandblasted and quality coated corrosion class C4-high
- **Information display in truck cabin**
 - Tank level indication
 - Temperature in tank 1 and batch tank

For questions and requests for further information please contact:

Vestergaard Company A/S

Skullejerg 31 • Gevninge
DK-4000 Roskilde • Denmark
Tel: +45 4642 2222
sales@vestergaardcompany.com
www.vestergaardcompany.com

Vestergaard Company Inc.

1903 W. Rte. 120
McHenry, IL 60051 • USA
Tel: +1 815 759-9102
Toll free: +1 888 759-9118
usa@vestergaardcompany.com

Vestergaard Company SASU

Bâtiment 3450 A, 4, Rue du Té
93290 Tremblay-en-France • France
Tel.: +33 1 30 34 55 87
france@vestergaardcompany.com

Vestergaard Company Ltd.

Pinthong Industrial Estate
789/50 Moo 1, Nongkham
Chonburi 20230 • Thailand
Tel: +66 (0) 38 348 630
asia@vestergaardcompany.com

Caution: Specifications are advisory only, and will vary. Please request exact data.

