

AIRCRAFT WASHER



When fuel efficiency and appearance are important to your organization, then keeping your aircraft washed regularly is necessary. Vestergaard Company has developed an open-basket aircraft washer based on the very successful Elephant MY deicer (7-800 in use around the world).

The aircraft washer has a specially designed basket with soft safeguards and optional protection systems for safe driving and maneuvering.

The washer can be delivered with a separate detergent tank and a mixing system. Optionally you can also choose to have a heater and of course it can be delivered with one-man operation.

The Elephant MY Aircraft Washer can be delivered on a Volvo diesel chassis or on the Vestergaard e electrical chassis.

MAJOR ADVANTAGES

- » Based on proven technology
- » Highly reliable in operation
- » First-class workmanship
- » Safe maneuvering around the aircraft



For questions and requests for further information please contact:

Vestergaard Company A/S

Skullebjerg 31 • Gevninge
DK-4000 Roskilde • Denmark
Tel: +45 4642 2222
sales@vestergaardcompany.com
www.vestergaardcompany.com

Vestergaard Company Inc.

1903 W. Rte. 120
McHenry, IL 60051 • USA
Tel: +1 815 759-9102
Toll free: +1 888 759-9118
usa@vestergaardcompany.com

Vestergaard Company SASU

Bâtiment 3450 A, 4, Rue du Té
93290 Tremblay-en-France • France
Tel.: +33 1 30 34 55 87
france@vestergaardcompany.com

Vestergaard Company Ltd.

Pinthong Industrial Estate
789/50 Moo 1, Nongkham
Chonburi 20230 • Thailand
Tel: +66 (0) 38 348 630
asia@vestergaardcompany.com

AIRCRAFT WASHER

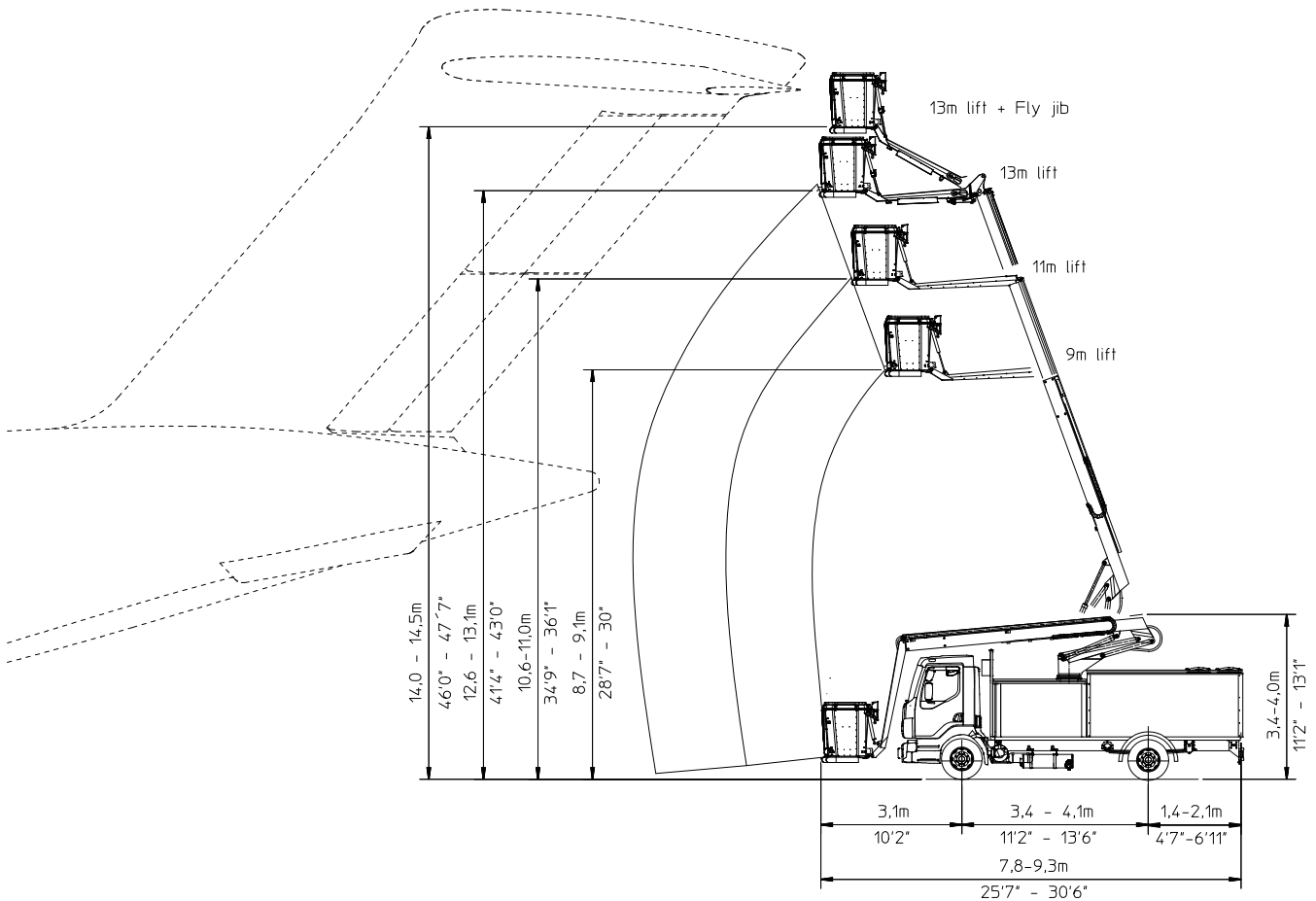

Specifications:

Maximum lifting height: see above
Overall height (typically): 3.8 m (12'6")
Overall width (typically): 2.6 m (8'7")
Overall length (typically): 9.0 m (29'6")

All above mentioned data are chassis dependent

Total tank capacity:

4000*, 5600 or 7600 litres
(1060*, 1480 or 2010 gal US)

One or two tank configuration available.

Weight (empty tanks): 8.5 - 12.5 Tons (metric)

Hot water option available.

One-man (drive from basket) option available.

Fluid selections:

Standard	100%	Water
	100%	Detergent
Option	5-20%	Detergent mix

Efficient corrosion protection: lifting basket in aluminum, coating of hollow frame members internally, sandblasting and metallizing of exposed areas before painting with primer, undercoat and top enamel.

** Only up to 11 meters reach for small tank aircraft washers (dependent on chassis)*