

ELEPHANT[®]MY

DE-ICING SYSTEMS

AIRCRAFT SERVICE TRUCKS



COMPANY
VESTERGAARD

THE MOST VERSATILE OPEN BASKET AIRCRAFT DEICER THE ELEPHANT[®] MY



The Elephant[®] My provides the customer with the Forced Air System, which ensures highly efficient snow removal with the maneuverable nozzle and the shortest possible blow distance.

The design of the Elephant[®] My is based on Vestergaard Company experience and technology proven reliable over the years. The Elephant[®] My is built on a standard truck chassis and can be equipped with a vast array of options to increase its efficiencies while still keeping it simple.

THE MY CONCEPT

The core concept of the Elephant[®] My is to provide the customer with a highly efficient deicer to operate at sites where flexibility is required. It

is extremely easy to operate, highly maneuverable, and has a small turn radius.

The Elephant[®] My can also be used as a maintenance platform or in aircraft exterior cleaning. The unique boom system - rotating at its base - provides a very wide operating area and performs smooth proportional movements. The advanced boom suspension system provides an almost vertical lift movement improving stability and a horizontal reach in all working heights.

FLUID ECONOMY

Product development continuously generates numerous features to save fluid and minimize environmental impact.

FREEZE POINT+[®] FLUID MIX

The Vestergaard Proportional Mix System provides optimal blend according to actual weather conditions, thereby saving significant amounts of fluid. The blend system has industry leading deicing fluid mix accuracy, reaction time, and safety monitoring system.

Top-hinged doors on either side of the body provide an easy access to the machine room for service.



The Forced Air System provides highly efficient snow removal with the maneuverable nozzle and the shortest possible blow distance.



A standard chassis as selected by each customer, with automatic or hydrostatic transmission ensures availability of spare parts and easy maintenance.



HEATING SYSTEMS

In addition to the highly efficient Vestergaard heater, the Batch Heating System and the "Hot at Nozzle" system economically and effectively provide hot fluid to the nozzle at all times. The Batch Heating System ensures hot fluid (85°C/185°F) available virtually immediately after refilling.

A heat exchanger is available for operators who utilize heated Type II/IV fluids to maximize spraying temperature.

LOW FLOW FLUID APPLICATION

Thickened fluid can be applied in a uniform layer at low flow rate maintaining fluid properties.

DIAPHRAGM PUMPS

To minimize fluid degradation the Elephant[®] My fluid system is equipped with diaphragm pumps.

MANPOWER EFFICIENCY

The deicer can be optionally switched from two-man to one-man operation ensuring maximum manpower flexibility. In one-man operation mode all chassis movements are controlled from the operator's basket.

The optional Data Transmission System organizes, collects and processes the de-icing data of the de-icing fleet and can organize the dispatch of the de-icing fleet in order to optimize operations.

MAJOR ADVANTAGES

- » Proportionally controlled boom movements for smooth and safe operation
- » Optional one-man operation mode for ultimate flexibility
- » Short chassis wheel base for excellent maneuverability
- » Minimum degradation of fluids
- » Extremely easy to operate
- » One, two or three tank configuration
- » Single engine
- » Low maintenance costs

The Elephant[®] My provides operators with a highly efficient, reliable and safe deicer. It fully meets all customers' expectations of Vestergaard Company equipment:

- Unsurpassed quality
- Customization
- Outstanding documentation & support
- Technical hotline/customer service
- Low maintenance costs



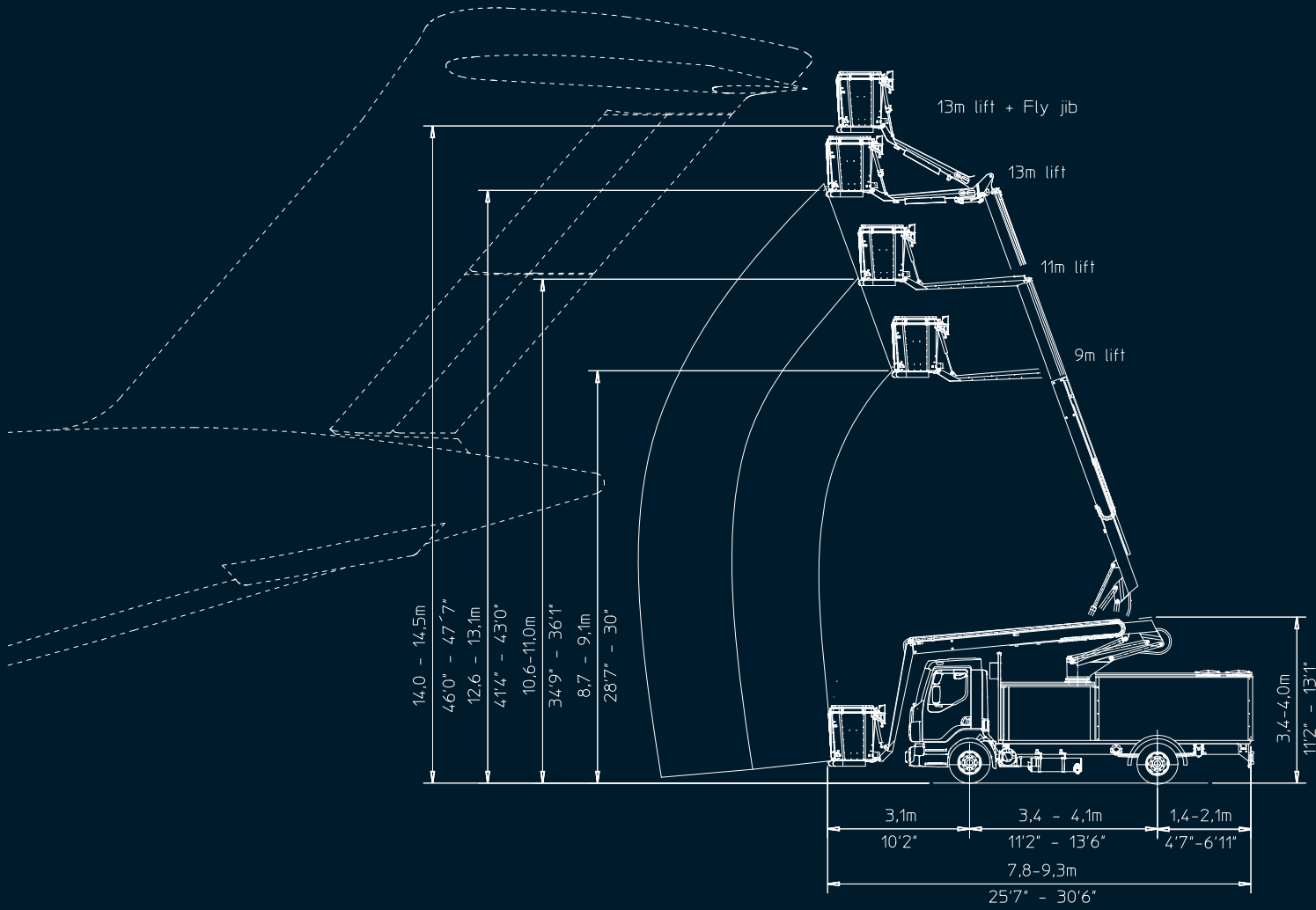

COMPANY
VESTERGAARD

Vestergaard Company A/S

Skullebjerg 31 • Gevninge
DK-4000 Roskilde • Denmark
Tel: +45 4642 2222
Fax: +45 4642 2232
sales@vestergaardcompany.com
www.vestergaardcompany.com

Vestergaard Company Inc.

1721 N. Oak Drive
McHenry, IL 60050 • USA
Tel: +1 815 759-9102
Fax +1 815 759-9103
Toll free: +1 888 759-9118
usa@vestergaardcompany.com

Vestergaard Company SASU

17 L route de Creil
95340 Bernes sur Oise • France
Tel.: +33 1 30 34 55 87
france@vestergaardcompany.com

Caution: Specifications are advisory only, and will vary. Please request exact data.